

Technical data sheet

Product features



Cooking range induction electric

Model	SAP Code	00014757
--------------	-----------------	----------



- Device type: Electric unit
- Power consumption of the zone 1 [kW]: 3,5
- Power consumption of the zone 2 [kW]: 3,5
- Protection of controls: IP24
- Material: AISI 304

SAP Code	00014757	Power electric [kW]	7.000
Net Width [mm]	400	Loading	400 V / 3N - 50 Hz
Net Depth [mm]	730	Number of zones	2
Net Height [mm]	300	Power consumption of the zone 1 [kW]	3,5
Net Weight [kg]	42.00	Power consumption of the zone 2 [kW]	3,5

Technical data sheet

Technical drawing



Cooking range induction electric

Model

SAP Code

00014757

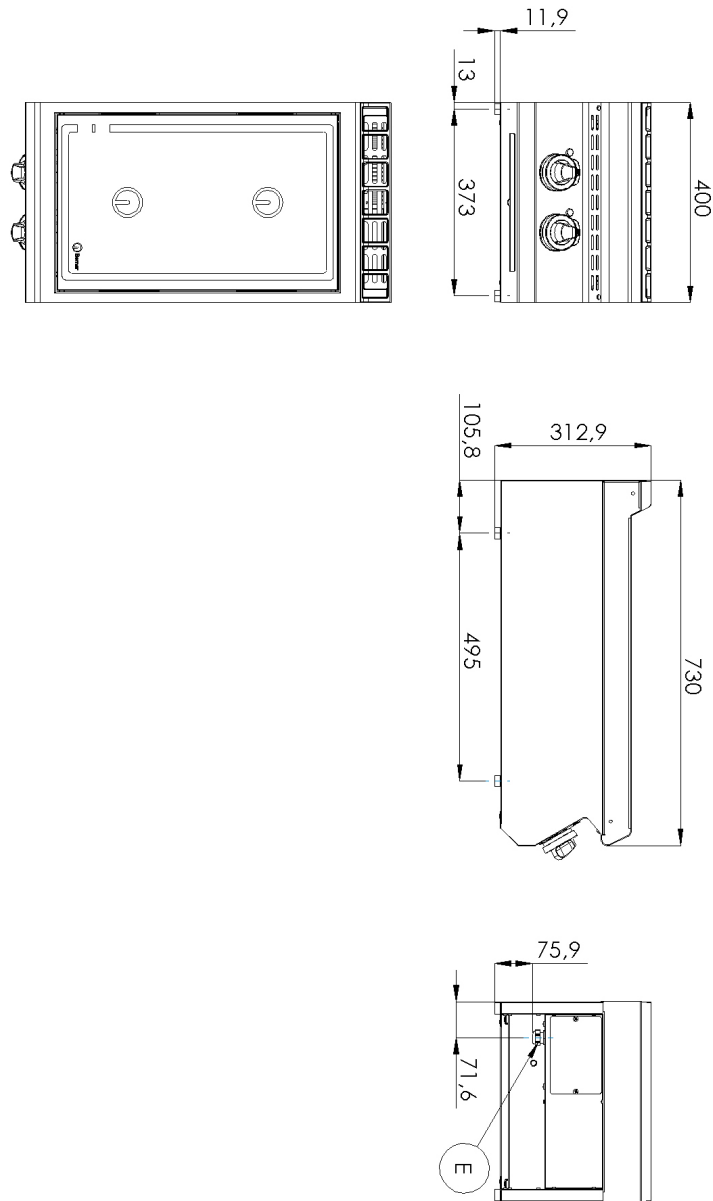

Technical data sheet

Technical parameters



Cooking range induction electric

Model

SAP Code

00014757

1. SAP Code:

00014757

2. Net Width [mm]:

400

3. Net Depth [mm]:

730

4. Net Height [mm]:

300

5. Net Weight [kg]:

42.00

6. Gross Width [mm]:

460

7. Gross depth [mm]:

820

8. Gross Height [mm]:

480

9. Gross Weight [kg]:

48.00

10. Device type:

Electric unit

11. Construction type of device:

Table top

12. Power electric [kW]:

7.000

13. Loading:

400 V / 3N - 50 Hz

14. Protection of controls:

IP24

15. Exterior color of the device:

Stainless steel

16. Material:

AISI 304

17. Indicators:

operation

18. Worktop type:

Molded - comfortable cleaning maintenance

19. Worktop material:

AISI 304

20. Worktop Thickness [mm]:

1.50

21. Number of zones:

2

22. Power consumption of the zone 1 [kW]:

3,5

23. Power consumption of the zone 2 [kW]:

3,5

24. Service accessibility:

Trough the frontal panel

25. Number of burners/hot plates:

2

26. Type of electric cooking zones:

Induction